

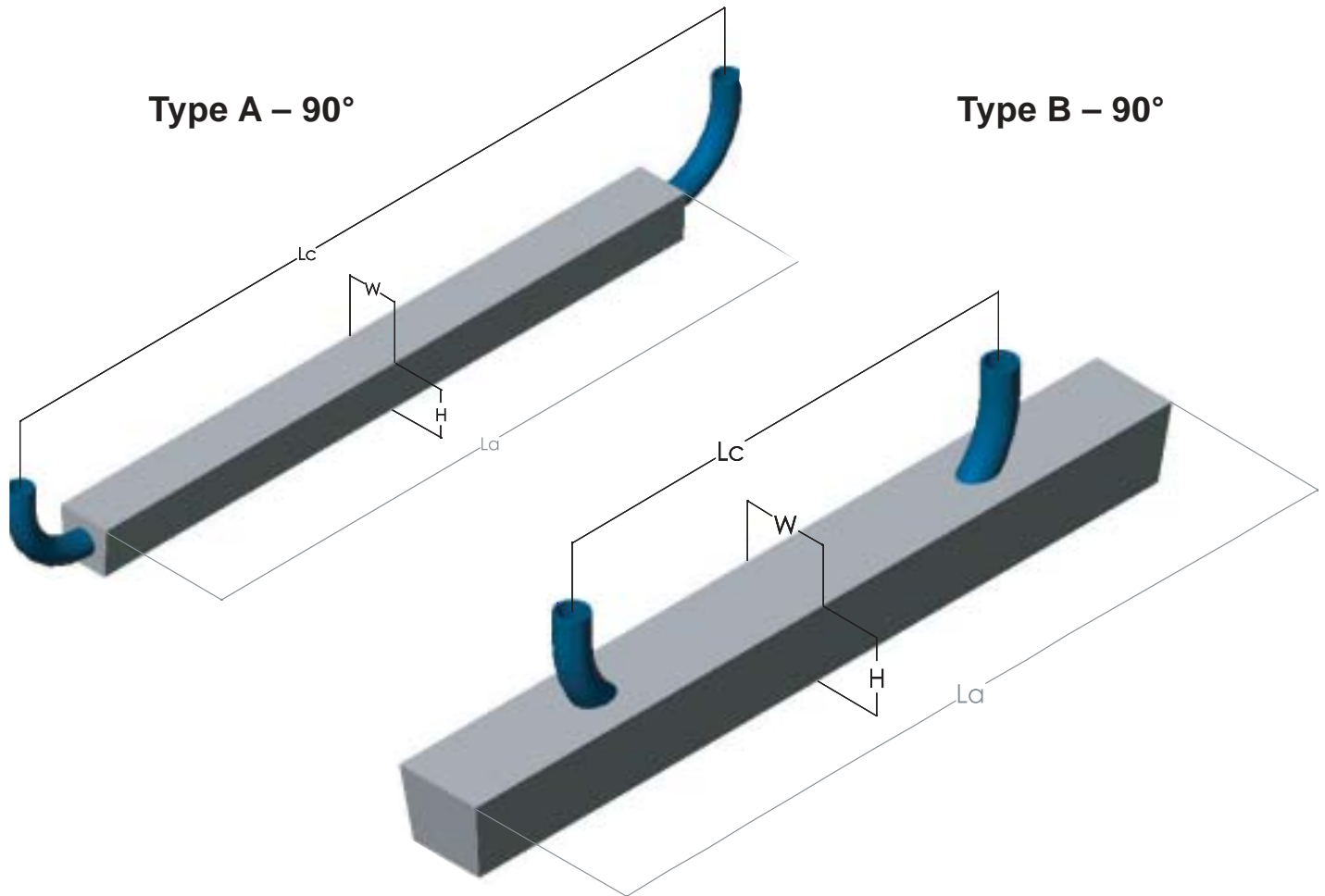

Aluminum Platform/Structural Anodes



Platform Anode with 90° Bent Pipe Core



Net Wt.		W		H		La		Anode Type	Lc		Core Specification Pipe Size
lbs	Kg	in	mm	in	mm	ft.	mm		ft.	mm	
325	147.4	6	160	6	163	8	2438	A	10.0	3048	2" Schedule 80
								B	7.0	2134	2" Schedule 80
411	222.3	7	208	7	188	8	2438	A	11.0	3353	3" Schedule 80
								B	7.0	2134	3" Schedule 80
540	244.9	8	208	8	203	8	2438	A	11.0	3353	3" Schedule 80
								B	7.0	2134	3" Schedule 80
725	328.9	9	249	9	239	8	2438	A	10.7	3261	4" Schedule 80
								B	7.0	2134	4" Schedule 80
1050	476.3	9	229	9	249	12	3658	A	13.7	4176	4" Schedule 80
								B	10.0	3048	4" Schedule 80
1250	567.0	10	249	10	267	12	3658	A	13.7	4176	4" Schedule 80
								B	10.0	3048	4" Schedule 80



Aluminum Platform/Structural Anodes



Platform Anode with 45° Bent Pipe Core

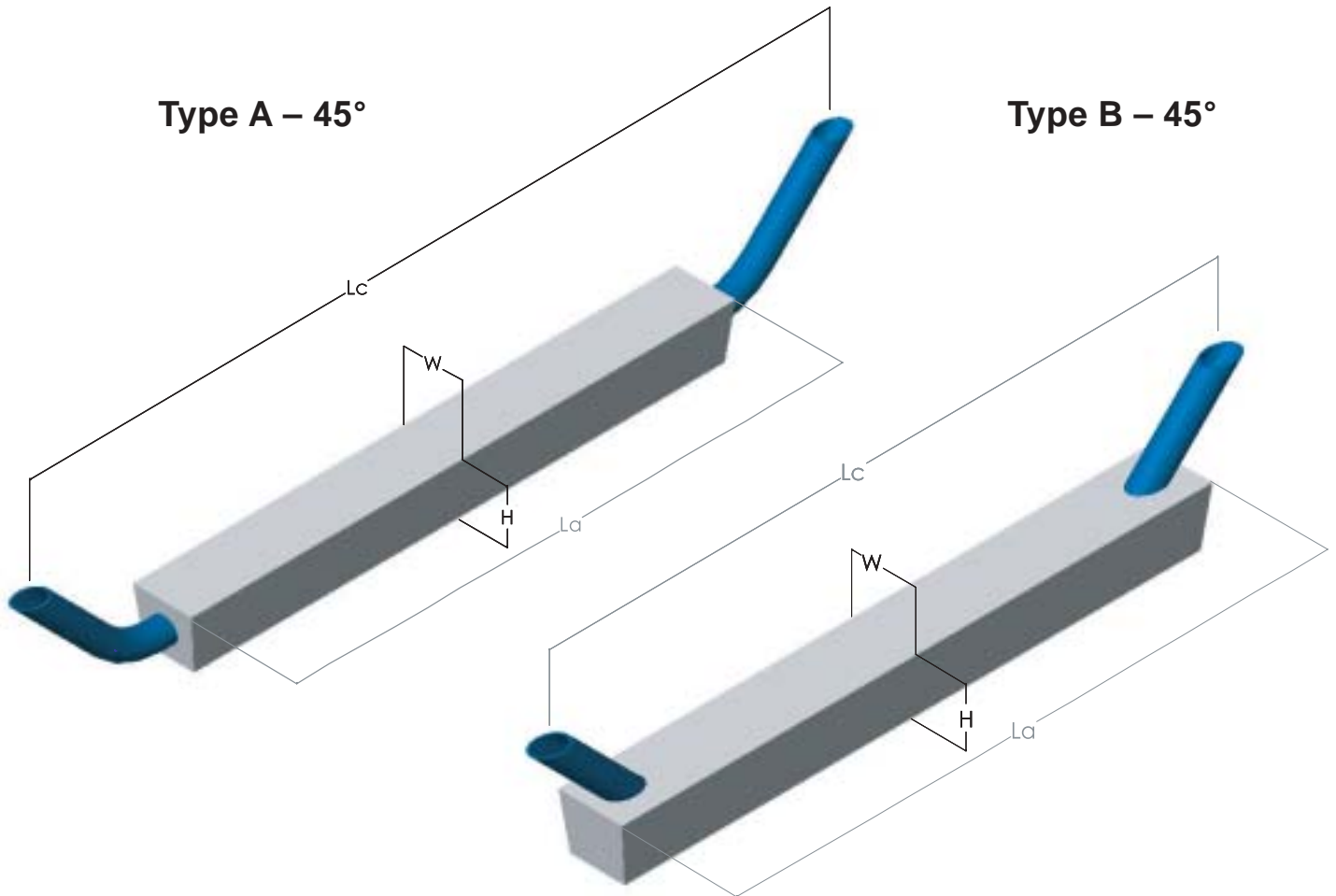

Net Wt.		W		H		La		Anode Type	Lc		Core Specification Pipe Size
lbs	Kg	in	mm	in	mm	ft.	mm		ft.	mm	
325	147.4	6	160	6	163	8	2438	A	11.0	3353	2" Schedule 80
								B	9.0	2743	2" Schedule 80
411	222.3	7	208	7	188	8	2438	A	11.5	3505	3" Schedule 80
								B	9.0	2743	3" Schedule 80
540	244.9	8	208	8	203	8	2438	A	11.5	3505	3" Schedule 80
								B	9.0	2743	3" Schedule 80
725	328.9	9	249	9	239	8	2438	A	12.0	3658	4" Schedule 80
								B	9.0	2743	4" Schedule 80
1050	476.3	9	229	9	248	12	3658	A	16.0	4877	4" Schedule 80
								B	13.0	3962	4" Schedule 80
1250	567.0	10	249	10.8	267	12	3658	A	16.0	4877	4" Schedule 80
								B	13.0	3962	4" Schedule 80